

FASTFOOT® INSTALLATION

1 SETUP SCREED BOARDS

Layout the outside footing stakes (steel or 1x4s) around the perimeter using a string line.

Drive the stakes on this line about 6' on center. Reduce spacing for deeper footings or if the ground is less dense.

Drive inside stakes opposite each outside stake using a 1x2 cut to the footing width.

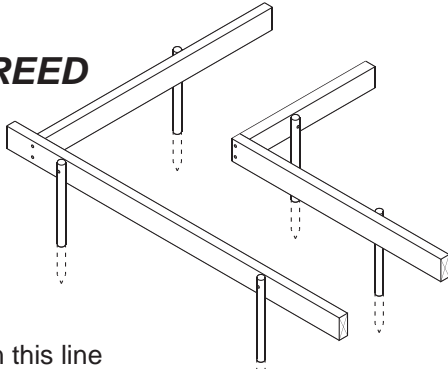

SOLIDLY ATTACH SCREED BOARDS
Concrete produces downward tension in fabric. Use 3 nails or 2 screws (2-1/4") per stake.

2 INSTALL FASTFOOT®

Pull Fastfoot® between stakes and nail center line to ground to prevent shifting. Allow 10" overlap on all joints.

Place one hand on correct width line (see table) on the ground and bring fabric edge snugly over the screed board. Staple in position using a hammer tacker with 3/8" staples about 12" on center. Reduce spacing for deeper footings.

Ensure the two edges are in line by using line-dots located every 14" along edge lines. Use edge lines for alignment when grade does not change.

Attach 1x4s across screed boards to prevent side deflection from concrete. Hang steel reinforcing from 1x4s. Ready for concrete.

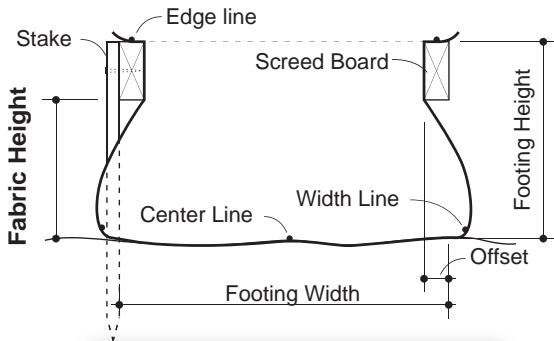
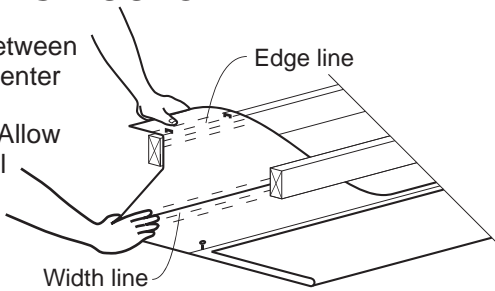

15" FABRIC HEIGHT RULE
If fabric height is greater than 15", install second 2x4 to reduce bulge and tension.

TOOLS & SUPPLIES

Sharp scissors, hammer tacker with 3/8" staples, 2" tape, hammer, skill saw, stake nails or screws, stakes, 2x4s, 3/4" plywood for steps, 1x4s for cleats.

CORNERS

1st

Run Fastfoot® past corner. Nail off centerline and corner diagonal. Staple fabric in position up to corner.

Cut fabric edge to footing width line as shown, then along the width line to the inside corner. Cut up the width line an equal distance. Staple #1 tab to screed board.

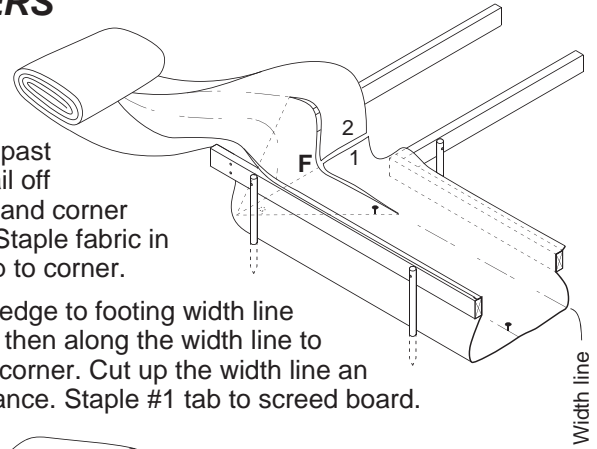

2nd

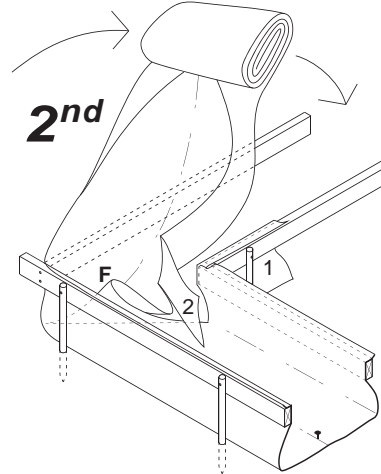

Lift fabric up at F, pivoting the roll around outside corner until aligned in new direction.

3rd

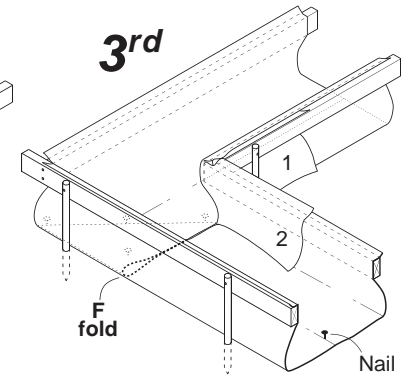

Lay down fold F and nail. Staple tab #2 to screed board.

T-JUNCTIONS

Run fabric through junction. Cut an 'inverted T' in junction area with lower cut along footing width line. Fold and staple tabs. Run intersecting fabric into junction allowing a 10" overlap. Cut overlap along footing width line, and staple overlapping tabs to screed boards.

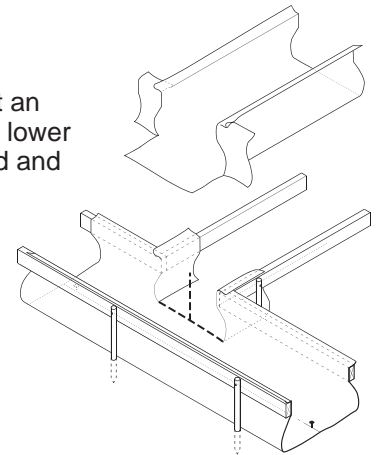

FOOTING WIDTH LINES

Color	Width
Lt Blue	12"
Red	16"
Yellow	20"
Green	24"
Blue	28"
Brown	32"
Purple	36"

FULL FOOTING SIZING CHART

Fabric width	Fabric Name	Footing Max. Size
37"	Edging	NA
50"	Narrow	10" x 18"
62"	Standard	13" x 24"
74"	Wide	13" x 36"

FABRIC WIDTH SIZING RULE

Equals footing width + twice height + 12".

FAB-FORM INDUSTRIES LTD.

www.fab-form.com

Toll free: (888) 303-FAST (3278)

DAMP PROOFING

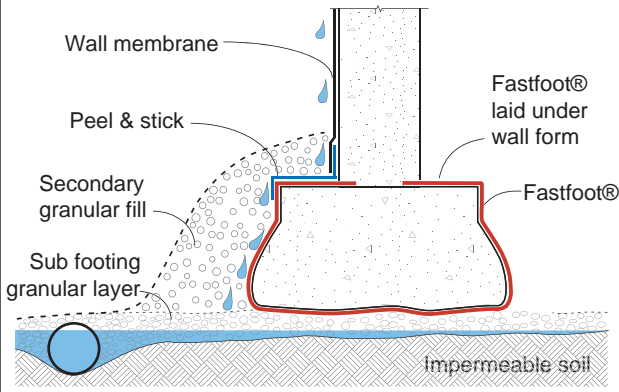

Leave screed boards, stakes in position. Pull Fastfoot® off screeds and lay flat on top of footing. Form and pour wall. On the outside, run a 12" width of peel & stick membrane along top of footing (covering staple holes in Fastfoot®) and up side of wall. Lap bottom edge of wall membrane over vertical peel & stick. On the inside, tape underslab membrane to interior Fastfoot®.

STEP INSTALLATION

Drive pairs of 2x4 stakes into the ground and screw to upper and lower screed boards. Trim upper screed boards flush with vertical stakes. Drive additional stakes if the distance between the stake and bank is greater than 15". Install lower level fabric.

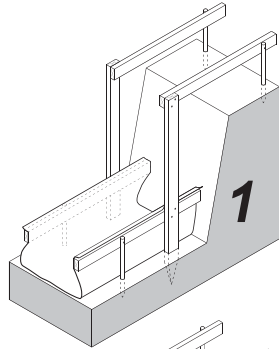

Run fabric up bank to form step. Most steps are too deep to form with a single fabric width. Either run two widths of fabric as edging or turn the fabric 90 degrees to obtain the required width.

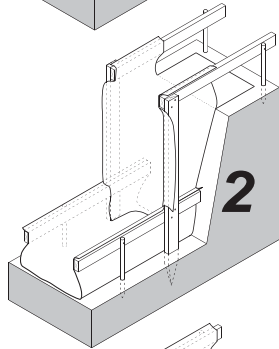

Install the upper level fabric with an 10" overlap. Cut the overlap on the footing width line, letting center portion hang down bank.

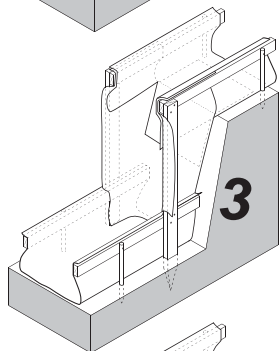

Screw plywood bulkhead in position and brace as required.

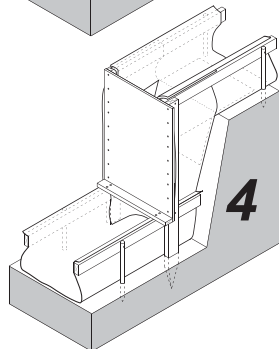

Step fabric can also be installed without cutting, see website for installation details.

EDGING INSTALLATION

1 SETUP SCREED BOARDS

Drive stakes around the perimeter of the proposed slab or footing at about 5' on center.

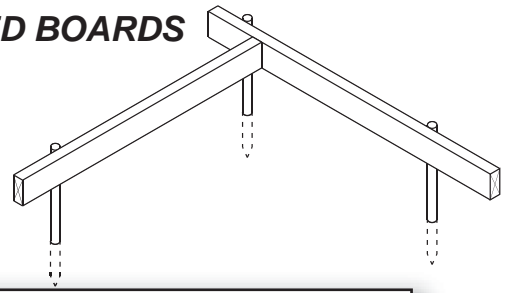

SOLIDLY ATTACH SCREED BOARDS
Concrete produces downward tension in fabric. Use 3 nails or 2 screws (2-1/4") per stake.

For slab edging use deeper edge lumber (2x6 or 2x8) if a flat face is required for exposed edge. For footings, drive stakes on the footing line, so the 1-1/2" will save concrete.

2 INSTALL FASTFOOT®

Staple the edge of the fabric to the top of the screed board using a hammer tacker with 3/8" staples on about 8" centers.

Provide sufficient slack in the fabric by using a 1x4 as shown to prevent excessive downward pressure. Nail fabric to ground at 4' centers to stop fabric pull-out from concrete pressure. Allow an 10" overlap on all joints.

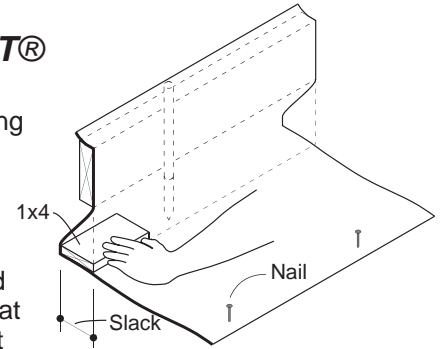

3 CORNERS

For outside corners, fold fabric on ground and nail through three layers to hold in position. For inside corner, cut fabric on the ground to enable it to go around corner and nail in position.

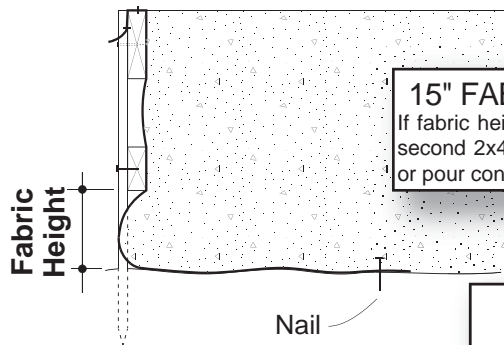
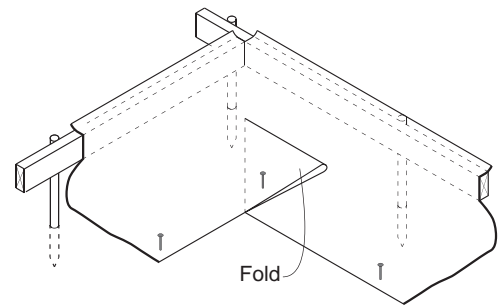

15" FABRIC HEIGHT RULE
If fabric height is greater than 15", install second 2x4 to reduce bulge and tension, or pour concrete in separate lifts.

EDGING SIZING CHART		
Fabric width	Fabric Name	Maximum Height
37"	Edging	16"
50"	Narrow	22"
62"	Standard	28"
74"	Wide	34"

FAB-FORM INDUSTRIES LTD.

www.fab-form.com

Toll free: (888) 303-FAST (3278)



www.GreenSpec.com

REQUIRED WIDTH
2 x concrete height + 6"